

Axialkolben-Doppelpumpe

**H3V112DTE für Hitachi Typ 9N00/9P00
EX200-1, 210-1, 220-1 anstatt HPV116-Pumpe**

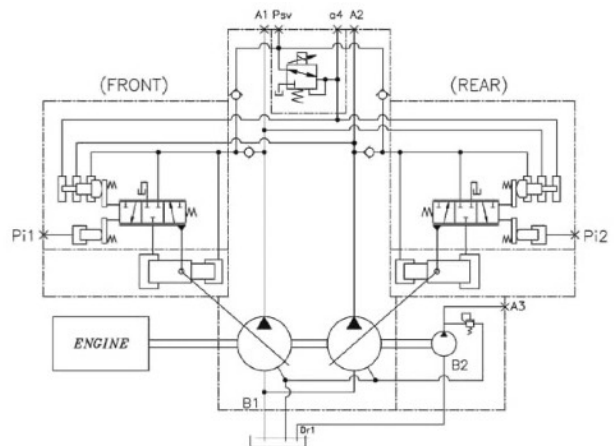
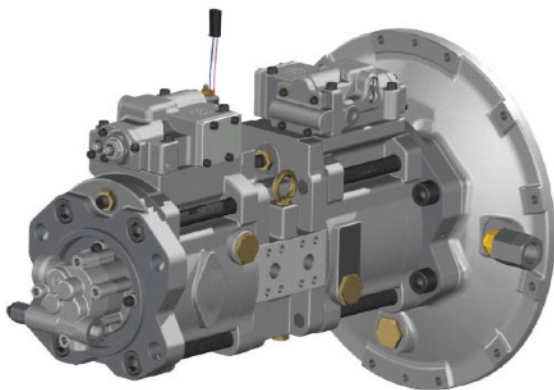

Spezifikationen

Model	Fördermenge (cm ³ /U)	Max. Druck (bar)	Max. Drehzahl (U/min)
H3V112DTE (EX200-1, 210-1, 220-1)	112	350	2150

Masse Wellenende

Model	Anzahl Zähne	∅ Aussen (mm)	Modul	Eingriffswinkel	Standard
H3V112DTE (EX200-1, 210-1, 220-1)	15	45	3	20°	JIS B 1603:1995

Masse (mm)

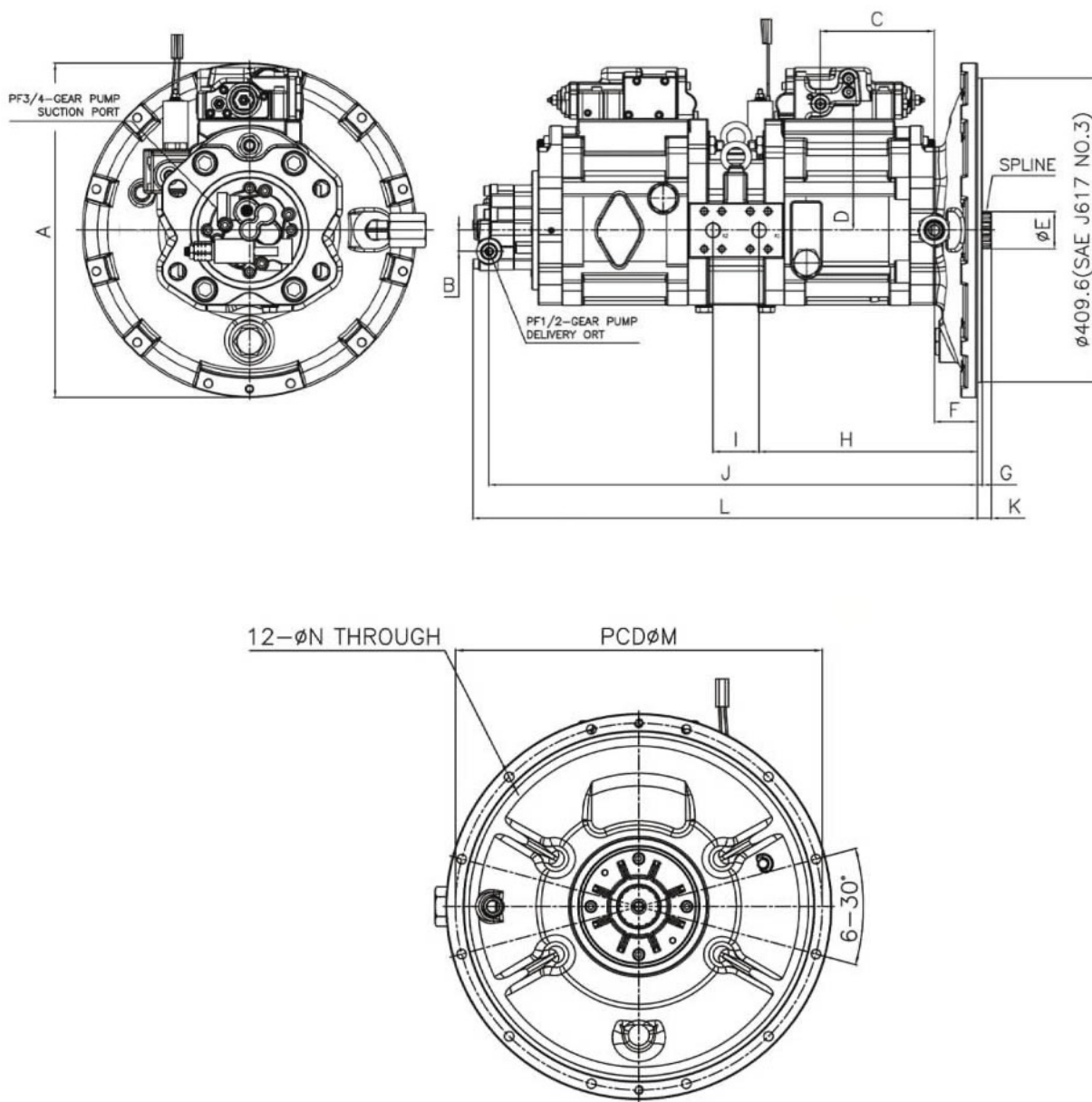

Model	A	B	C	D	E	F	G	H	I	J	K	L	M	N
H3V112DTE (EX200-1, 210-1, 220-1)	450	29	153	170	50	58	7	294	62	657.8	19.4	679.6	428	11