

Axialkolben-Doppelpumpe

H3V112DTPE für Hitachi Typ 3L09

EX200-2/3, 210-2/3, 220-2/3 anstatt HPVO91DW/EW-Pumpe

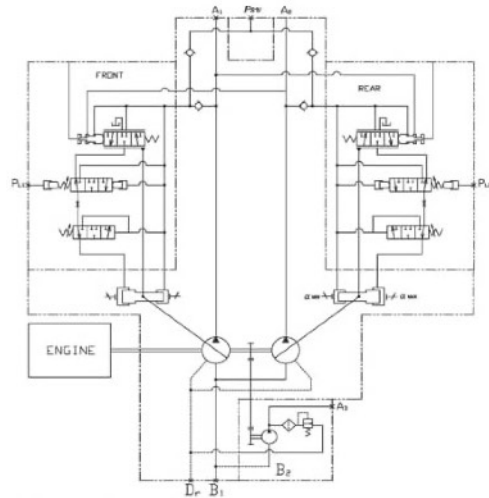
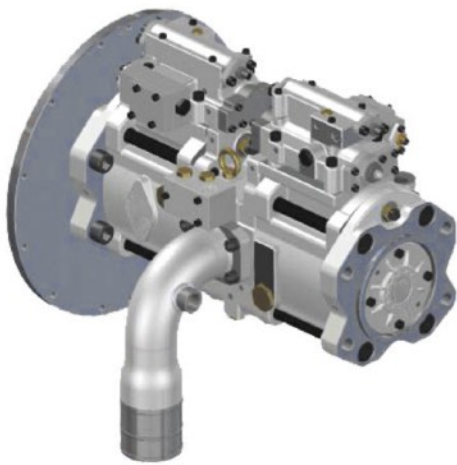

Spezifikationen

Model	Fördermenge (cm ³ /U)	Max. Druck (bar)	Max. Drehzahl (U/min)
H3V112DTPE (EX200-2/3, 210-2/3, 220-2/3)	112	350	1900

Masse Wellenende

Model	Anzahl Zähne	∅ Aussen (mm)	Modul	Eingriffswinkel	Standard
H3V112DTPE (EX200-2/3, 210-2/3, 220-2/3)	16	40	2.5	20°	JIS B 1603:1995

Masse (mm)

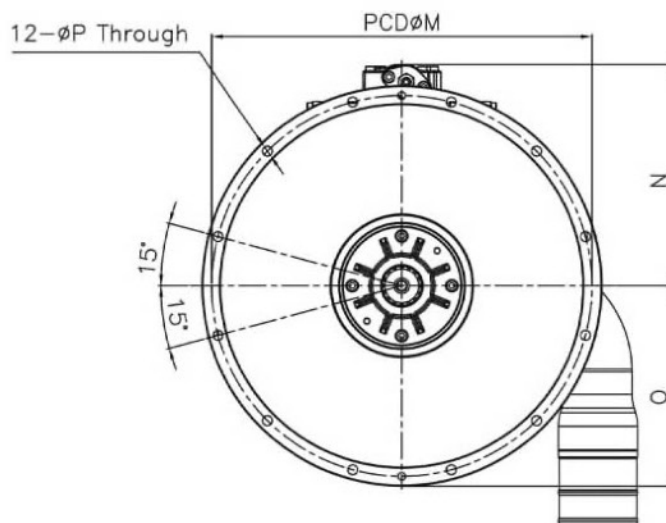
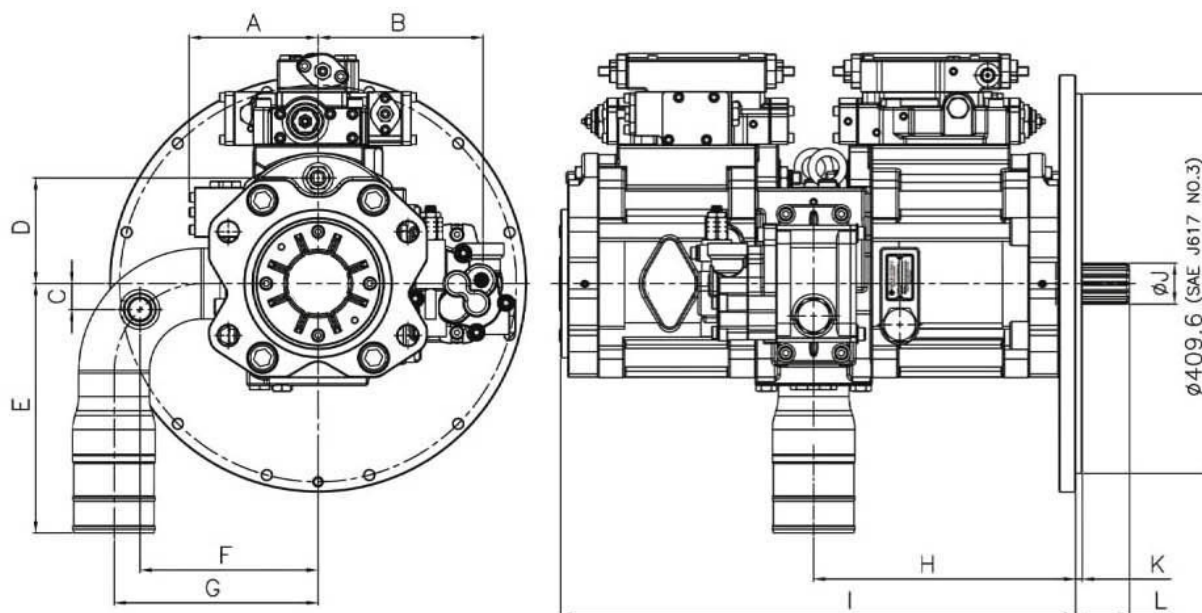

Model	A	B	C	D	E	F	G	H	I	J	K	L	M	N	O	P
H3V112DTPE (EX200-2/3, 210-2/3, 220-2/3)	139	178	28	114	269.2	192	220	283	556	44.4	7	58	428	248.6	225	11