

Hilfspumpe

für Uchida-Bagger

AP2D21, AP2D25, AP2D28, AP2D36 GP22



Spezifikationen

Model	Fördermenge (cm ³ /U)	Max. Druck (bar)	Max. Drehzahl (U/min)
AP2D21	12	210	2800
AP2D25	16.8		2600
AP2D28	18.8		2600
AP2D36	22		2200

Masse (mm)

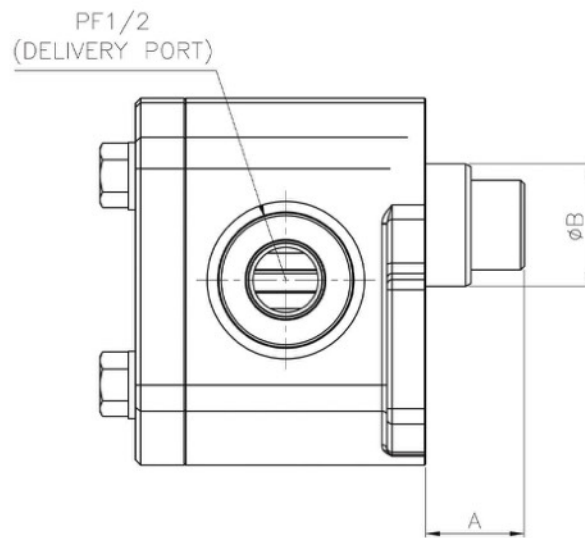
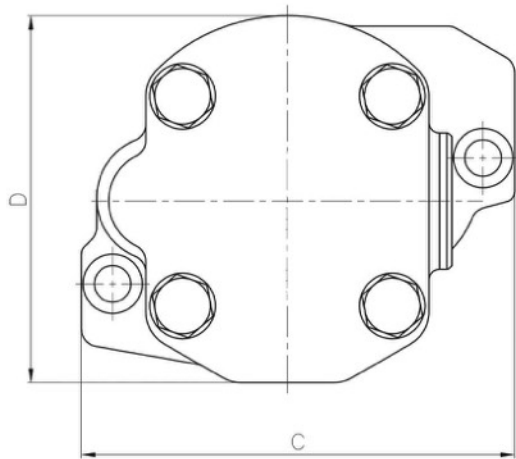
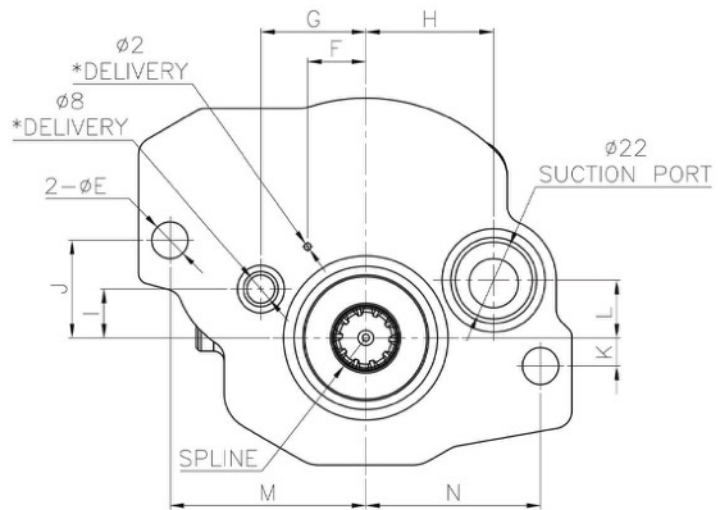

Model	A	B	C	D	E	F	G	H	I	J	K	L	M	N	Splin
AP2D21, AP2D25, AP2D28, AP2D36	28.6	35	124	105	10.5	16.7	30	36.6	14	28	8	16.5	56	50	Z10

Hilfspumpe

für Caterpillar-Bagger

AP2D25, AP2D28, AP2D36, AP2D38 (ZX60, ZX75, CAT307)

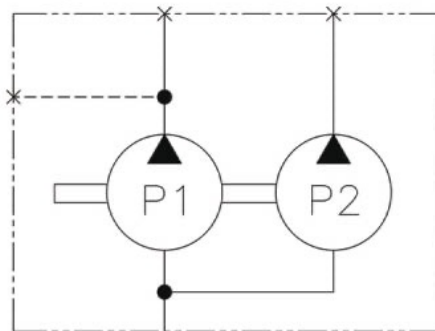

Spezifikationen

Model		Fördermenge (cm ³ /U)	Max. Druck (bar)	Max. Drehzahl (U/min)
AP2D25, AP2D28, AP2D36, AP2D38 (ZX60, ZX75, CAT307)	P1	21	210	2100
	P2	11	50	

Ansaugflansch ZX60 (AP2D25, AP2D28)

Ansaugflansch ZX75 (AP2D36, AP2D38)

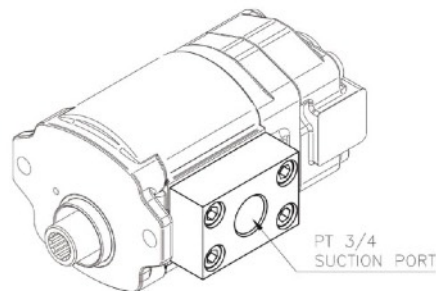
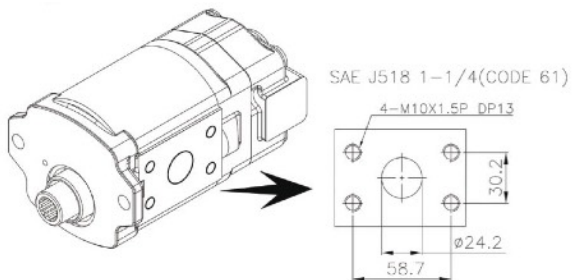

Masse (mm)

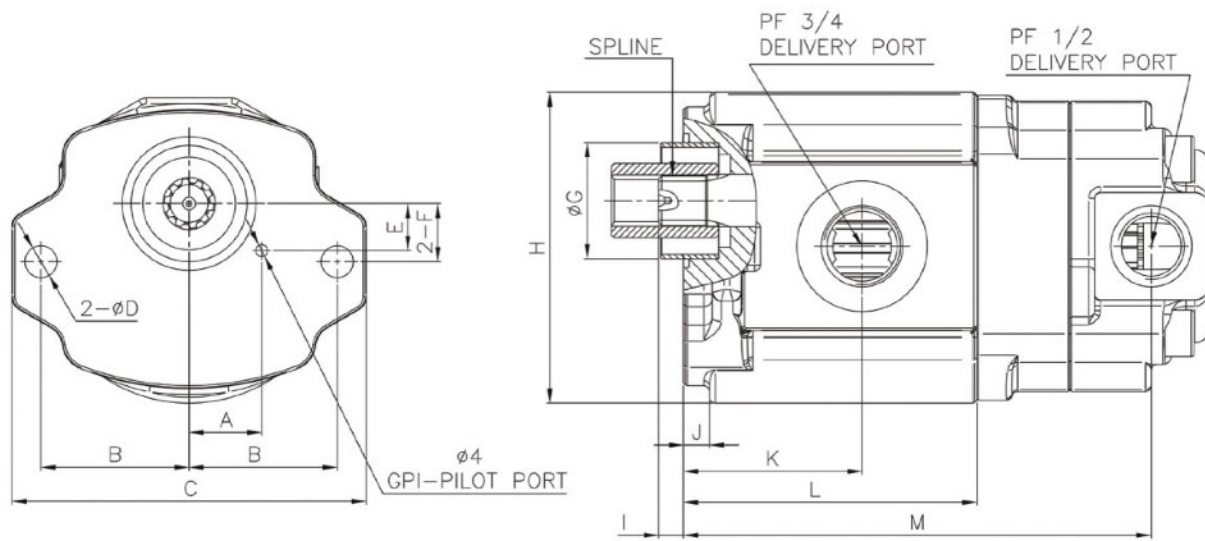

Model	A	B	C	D	E	F	G	H	I	J	K	L	M	Spline
AP2D25, AP2D28, AP2D36, AP2D38 (ZX60, ZX75, CAT307)	25	51	122	11	16.2	20	40	107	8.5	11	61.5	101	161	Z10