

Hilfspumpe

für Caterpillar-Bagger
SPK10-10 (E200B), AP12 (E200B)



Spezifikationen

Model	Fördermenge (cm ³ /U)	Max. Druck (bar)	Max. Drehzahl (U/min)
SPK10-10 (E200B)	12	170	3200
AP12 (E200B)			

Masse (mm)

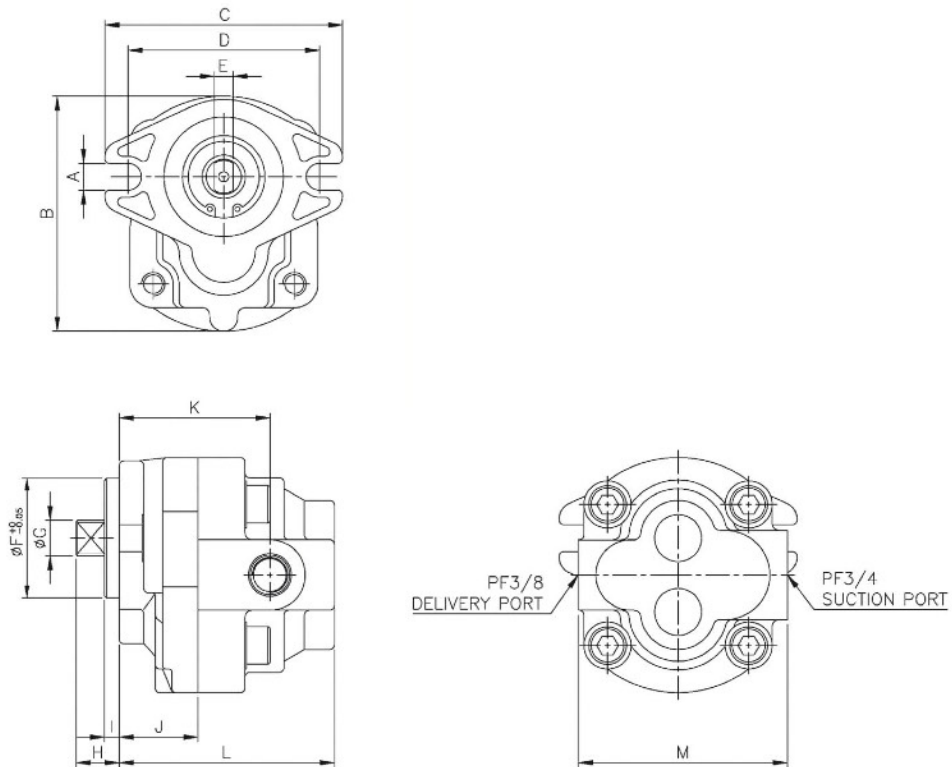

Model	A	B	C	D	E	F	G	H	I	J	K	L	M
SPK10-10 (E200B)	11.4	100	101	81.4	8	50.8	15	18.4	6.4	33.4	64	91.4	89
AP12 (E200B)													

Hilfspumpe

für Caterpillar-Bagger AP12 (E320B)



Spezifikationen

Model	Fördermenge (cm ³ /U)	Max. Druck (bar)	Max. Drehzahl (U/min)
AP12 (E320B)	11	170	3200

Masse (mm)

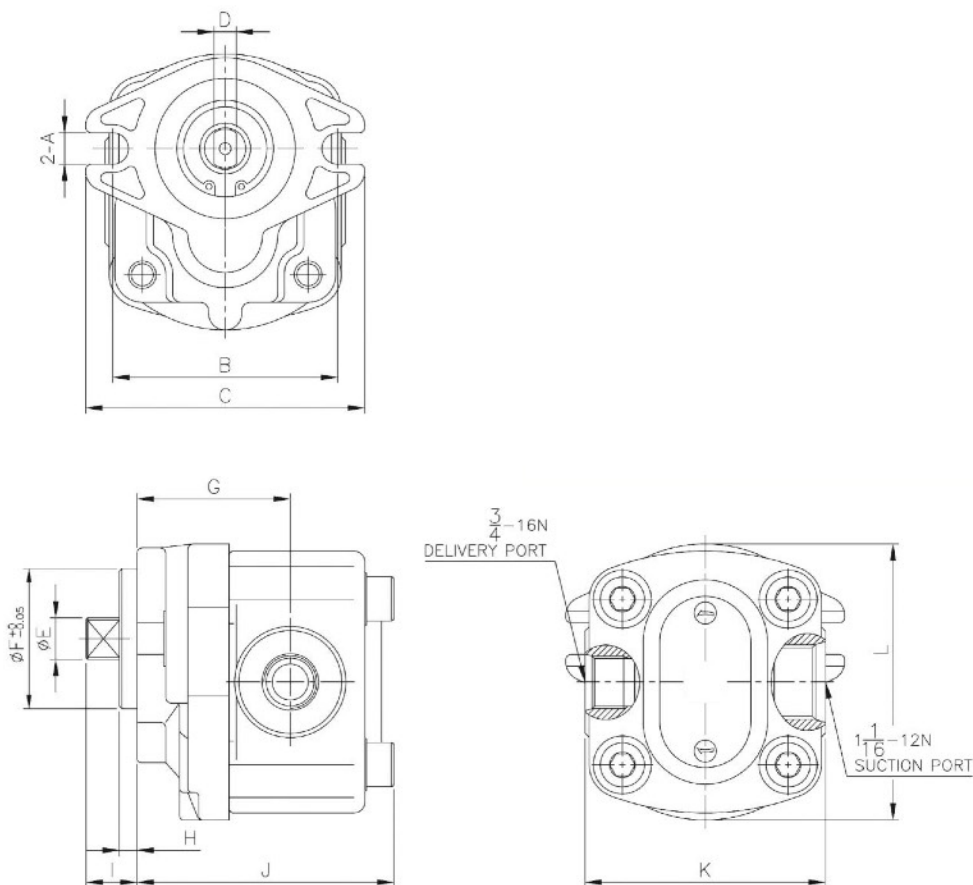

Model	A	B	C	D	E	F	G	H	I	J	K	L
AP12 (E320B)	11.4	81.4	101	8	16.5	50.8	63	6.4	18	99	87	100