

Hilfspumpe

für Kobelco-Bagger

H3V63, NV64, H3V112, NV90, NV111, H3V140, H3V180, NV137, NV172



Spezifikationen

Model	Fördermenge (cm ³ /U)	Max. Druck (bar)	Max. Drehzahl (U/min)
H3V63	12	170	3250
NV64			2700
H3V112			
NV90			
NV111	15	170	2500
H3V140			
H3V180			
NV137			
NV172			

Masse (mm)

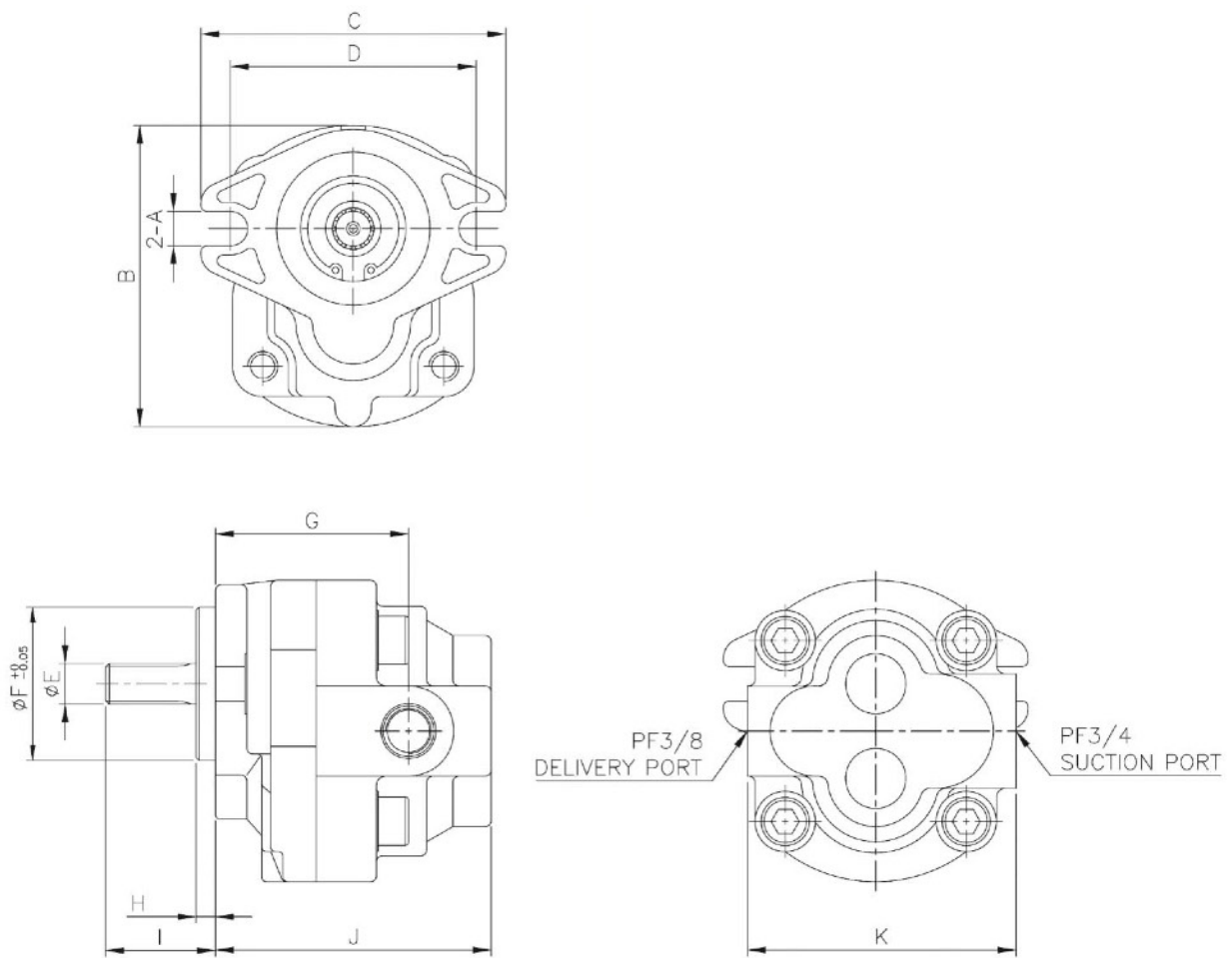

Model	A	B	C	D	E	F	G	H	I	J	K	Spline
Serie H3V/NV	11.4	100	101	81.4	13.5	50.8	64	6.4	37.7	91.4	89	Z12