

Hilfspumpe

H3V63DTP, H3V112DTP, H5V80DTP, H5V140DTP

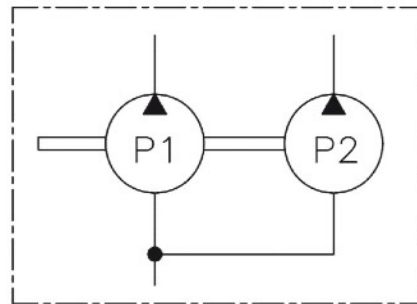

Spezifikationen

Model		Fördermenge (cm ³ /U)	Max. Druck (bar)	Max. Drehzahl (U/min)	Drehrichtung
H3V63DTP	P1	23	180	3200	CCW(L)
H5V80DTP					
H3V112DTP	P2	10/16			CW(R)
H5V140DTP					

Masse (mm)

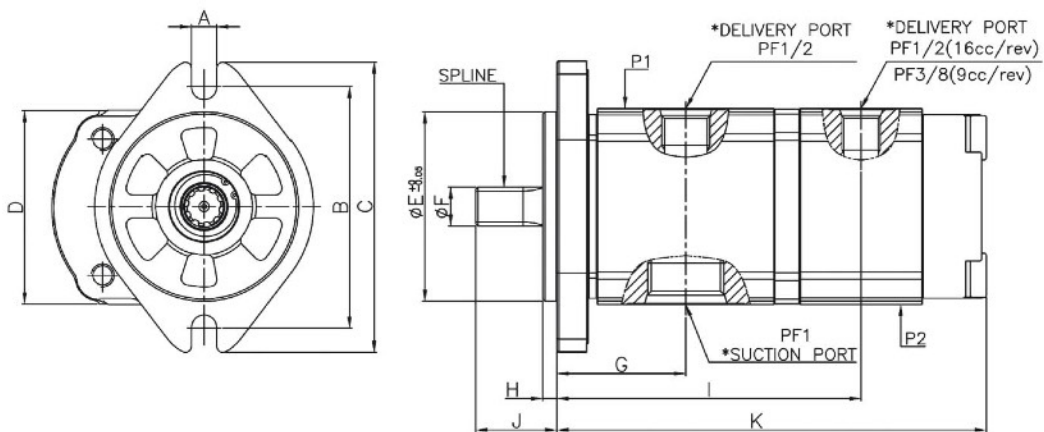

Model	A	B	C	D	E	F	G	H	I	J	K	Spline
H3V63DTP	11	106	127	85	82.55	17	56.3	6.2	134.1	35.4	190	Z10
H5V80DTP									138.7			
H3V112DTP									199.5			
H5V140DTP									199.5			