

# Hilfspumpe

## PSVD2-12, PSVD2-16, PSVD2-21, PSVD2-27

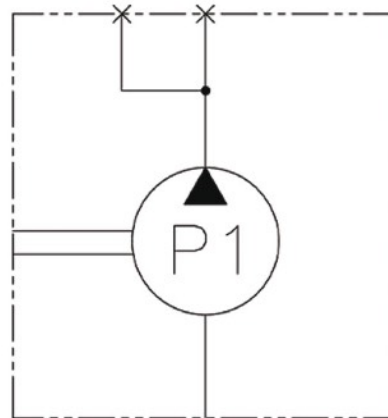
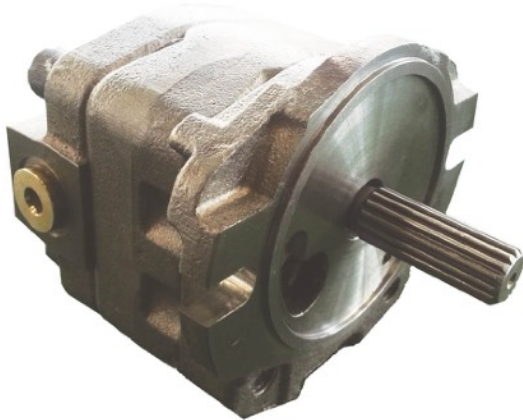

### Spezifikationen

Model	Fördermenge (cm <sup>3</sup> /U)	Max. Druck (bar)	Max. Drehzahl (U/min)
PSVD2-12	11.9	210	2400 2500 2550
PSVD2-16	14.3		
PSVD2-21	16.8		
PSVD2-27	19.2		

### Masse (mm)

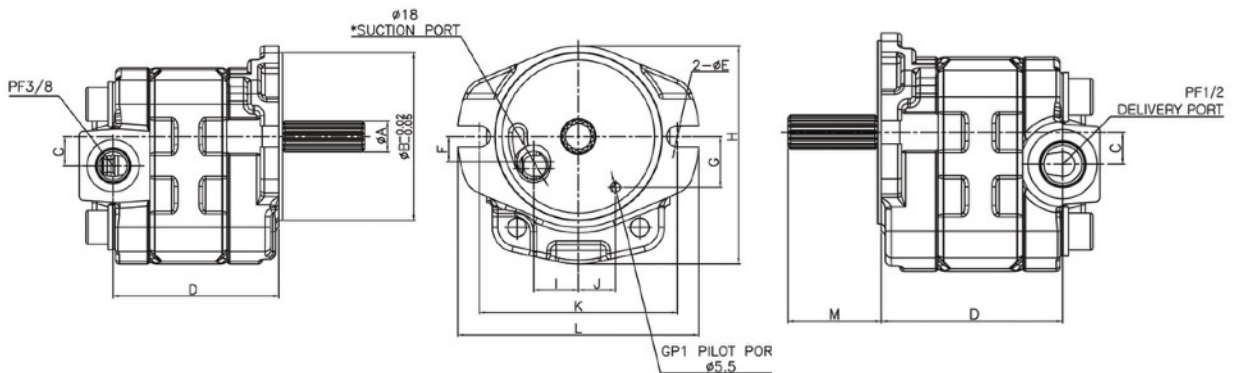

Model	A	B	C	D	E	F	G	H	I	J	K	L	M	Spline
PSVD2-12/16/21/27	17	90	15.7	89.2	11.5	13.5	27.3	116.7	24	19.8	106.4	129.5	46	Z15