

Hilfspumpe

PVD-1B-32P, PVD-2B-36P, PVD-2B-40P, PVD-2B-42P

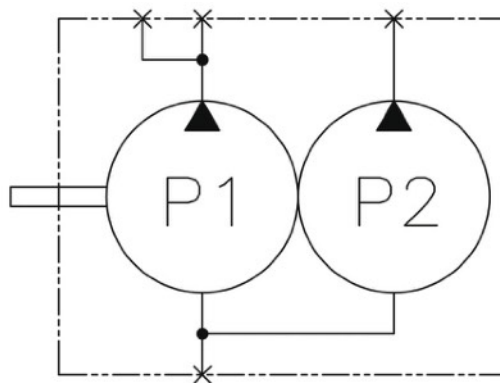

Spezifikationen

Model		Fördermenge (cm ³ /U)	Max. Druck (bar)	Max. Drehzahl (U/min)
PVD-1B	P1	10.5	210	3200
	P2	4.5	40	
PVD-2B	P1	16.5	210	
	P2	4.5	40	

Masse (mm)

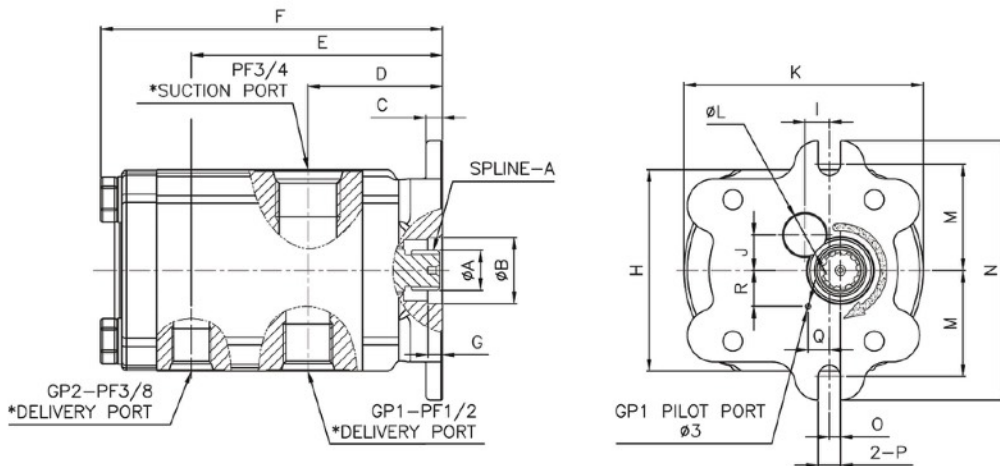

Model	A	B	C	D	E	F	G	H	I	J	K	L	M	N	O	P	Q	R	Splin
PVD-1B	17	28	7	59	96	135	6	85	10	15	102	18	45	110	4.7	9.5	9	15	Z10
PVD-2B					105	145													

Hilfspumpe

PVD-2B, PVD-3B, PVD-10.5+4.5, PVD-16.8+4.5

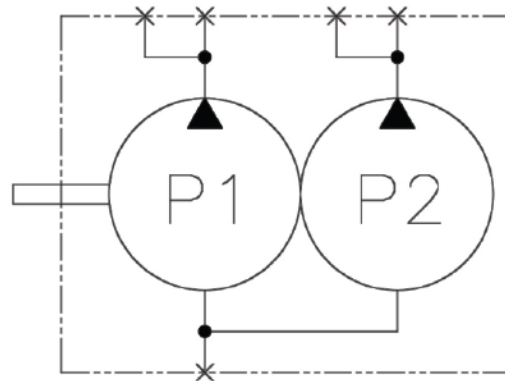

Spezifikationen

Model		Fördermenge (cm ³ /U)	Max. Druck (bar)	Max. Drehzahl (U/min)
PVD-2+3	P1	6	210	3000
	P2	3	40	
PVD-10.5+4.5	P1	10.5	210	
	P2	4.5	40	
PVD-16.8+4.5	P1	16.8	210	
	P2	4.5	40	

Masse (mm)

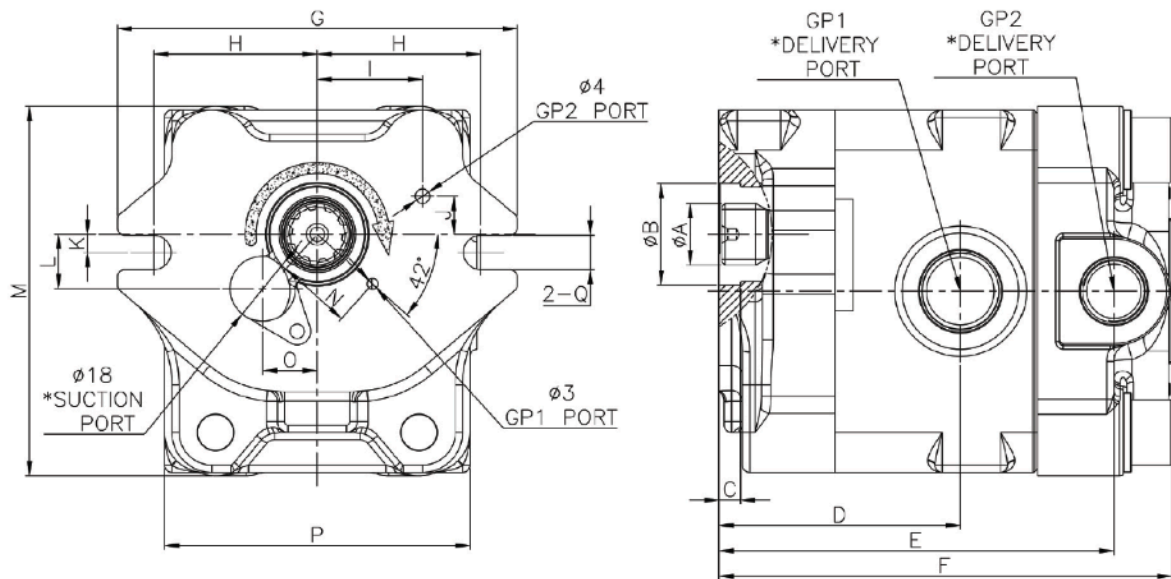

Model	A	B	C	D	E	F	G	H	I	J	K	L	M	N	O	P	Q	SPLINE
PVD-2+3				45.5	82.5	98.5												
PVD-10.5+4.5	17	28	6	49.5	91.5	108	110	45	29	10.5	5	15	102	20.5	15	84	9.5	Z10
PVD-16.8+4.5				66.5	108.5	125												