

# Axialkolben-Doppelpumpe

## HP2D36 für Hitachi

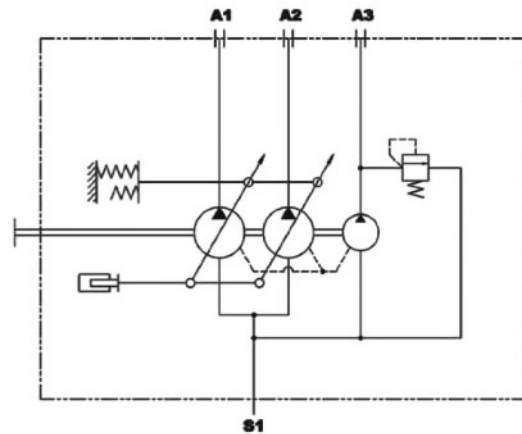
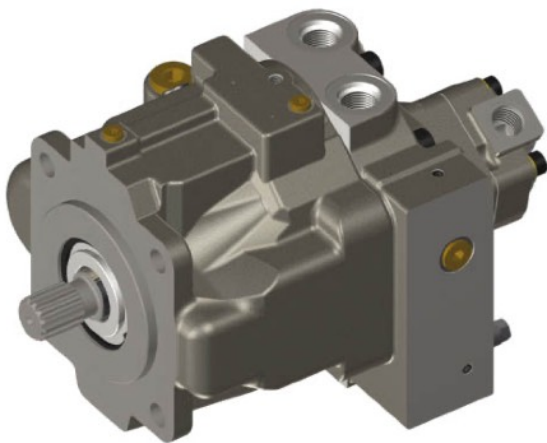

### Spezifikationen

Model	Fördermenge (cm <sup>3</sup> /U)	Max. Druck (bar)	Max. Drehzahl (U/min)
HP2D36 (Hitachi)	36	260	2200

### Masse Wellenende

Model	Anzahl Zähne	∅ Aussen (mm)	Modul	Eingriffswinke I	Standard
HP2D36 (Hitachi)	14	29.634	12/24	30°	SAE J498B
	15	22.5	1.5	20°	JIS B 1603:1995

### Ansaugflansch

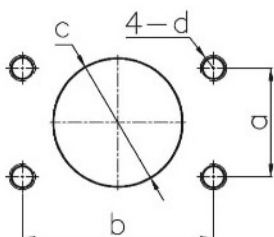

	mm
a	50.8
b	88.9
c	∅ 55
d	M12X1.75P DP18

Masse (mm)

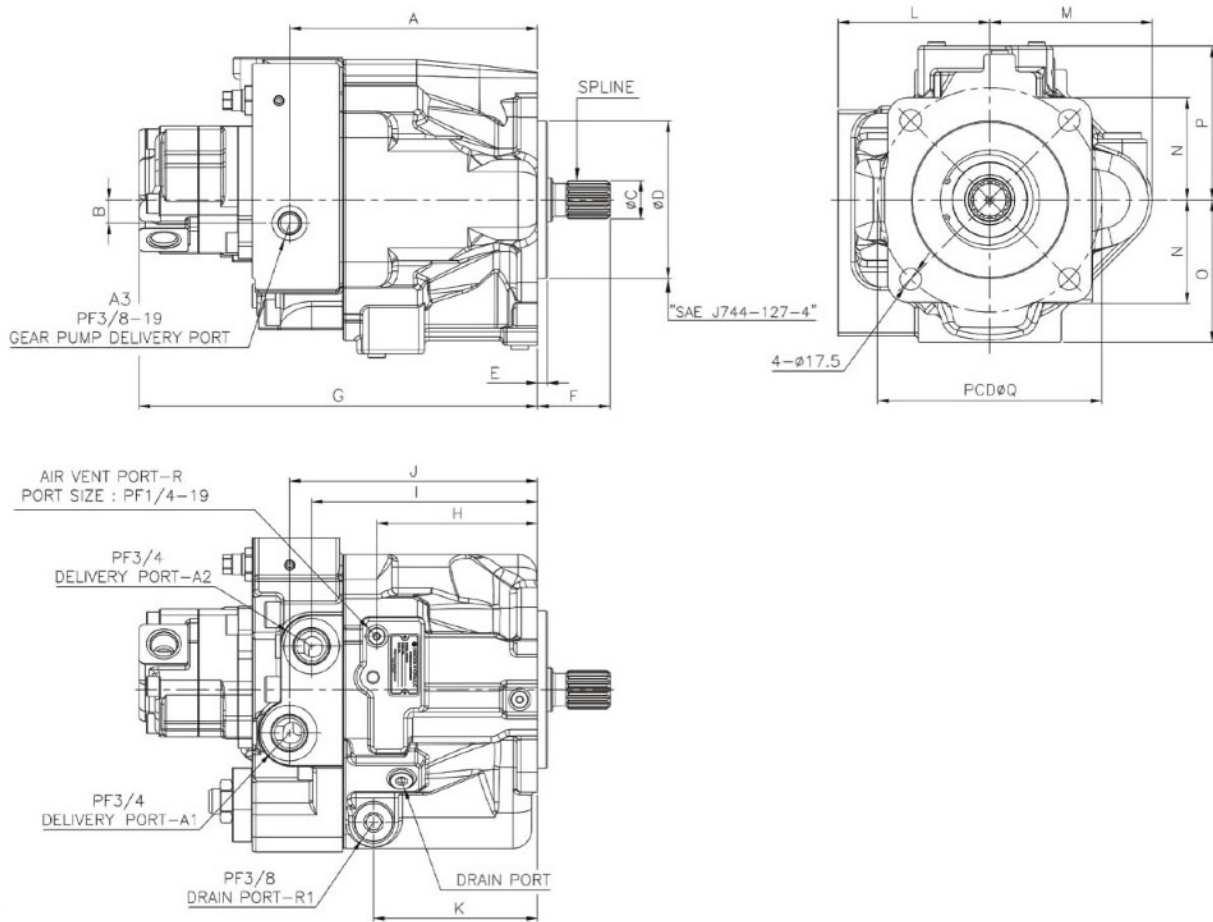

Model	Zähne	A	B	C	D	E	F	G	H	I	J	K	L	M	N	O	P	Q
HP2D36 (Hitachi)	14	200	18.8	31.2	127	8	58.8	321.7	129.7	182.2	200.2	132.3	122.5	131	82.5	115	124	181
	15			25														